

CONTINUOUS AND PULSED EPIDEMIOLOGICAL MODELS FOR ONCHOCERCIASIS WITH IMPLICATIONS FOR ERADICATION STRATEGY

GLENN LEDDER*

Department of Mathematics
University of Nebraska-Lincoln
Lincoln, NE 68588-0130, USA

DONNA SYLVESTER

Mathematics Department, 901 12th Ave.
Seattle University, P.O. Box 222000
Seattle, WA 98122-1090, USA

RACHELLE R. BOUCHAT

Department of Mathematics
Indiana University of Pennsylvania
Indiana, PA 15705

JOHANN A. THIEL

Department of Mathematics
New York City College of Technology - CUNY
Brooklyn, NY 11201, USA

(Communicated by the associate editor name)

ABSTRACT. Onchocerciasis is an endemic disease in parts of sub-Saharan Africa. Complex mathematical models are being used to assess the likely efficacy of efforts to eradicate the disease; however, their predictions have not always been borne out in practice. In this paper, we represent the immunological aspects of the disease with a single empirical parameter in order to reduce the model complexity. Asymptotic approximation allows us to reduce the vector-borne epidemiological model to a model of an infectious disease with nonlinear incidence. We then consider two versions, one with continuous treatment and a more realistic one where treatment occurs only at intervals. Thorough mathematical analysis of these models yields equilibrium solutions for the continuous case, periodic solutions for the pulsed case, and conditions for the existence of endemic disease equilibria in both cases, thereby leading to simple model criteria for eradication. The analytical results and numerical experiments show that the continuous treatment version is an excellent approximation for the pulsed version and that the current onchocerciasis eradication strategy is inadequate for regions where the incidence is highest and unacceptably slow even when the long-term behavior is the disease-free state.

2010 *Mathematics Subject Classification.* Primary: 92C60.

Key words and phrases. epidemiology, dynamical models, asymptotics.

This work was supported by NSF grant DMS 1239280.

* Corresponding author: Glenn Ledger.

1. **Introduction.** Onchocerciasis (known colloquially as “River Blindness”) is a vector-borne disease affecting the skin and eyes of humans. It is endemic in parts of Africa, Central America, and Yemen, with greater than 99% of the burden of onchocerciasis found in sub-Saharan Africa [3]. In Central America, Guatemala accounts for the largest at-risk population for onchocerciasis, but the disease has been designated as eradicated there [17]. It is caused by the filarial nematode *Ochocerca volvulus*, a parasitic worm with a complicated life cycle that includes five larval stages, labeled L1-L5, in Figure 1 [15]. Its life cycle includes stages that require a human host and stages that require a black fly host of the genus *Simulium*. The disease is listed by the World Health Organization as a neglected tropical disease, but it has been on the agenda of the Carter Center’s River Blindness Elimination Program.

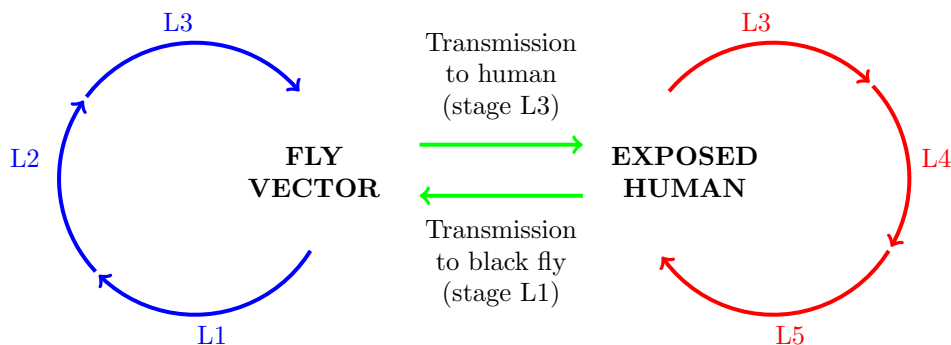

FIGURE 1. The *O. volvulus* life cycle, beginning with the microfilaria stage L1 in the human host. The microfilariae are transmitted to the black fly of the genus *Simulium* via a bite. Within the black fly, the larvae pass through larval stages L1-L3. At larval stage L3, they are transmitted to a human host via a bite, where they pass through the final larval stages L3-L5 and become adults [8].

If the microfilariae at stage L1 are not picked up by the vector, they can live in the host from 6 to 24 months. After the black fly of genus *Simulium* ingests the microfilariae at stage L1, it takes 6-12 days for the microfilariae to mature to stage L3. Through a *Simulium* bite, the stage L3 larvae enter the human host and take approximately a week to enter the final L5 larval stage. It takes an additional 7-15 months for these juvenile worms to mature to mating, with the adult worms having a life span of 10-14 years. At maturity, female worms produce 700-1500 microfilariae per day [8].

The black fly has peak biting times during the daylight hours and largely stays within 5km of their breeding sites on well-oxygenated water. Communities living on the river’s edge are more at risk than those further away, and it happens that the peak biting times of the vector correspond with the times when the exposed class of people are most likely to be at the river for activities such as gathering water or washing [8].

There are several medications that can help treat onchocerciasis, including *Diethylcarbamazine* and ivermectin (which are both microfilaricides) and Flubendazole (which is a macrofilaricide). Due to adverse or pronounced side effects of some of the medications, ivermectin (developed by Merck & Co Inc.) is considered to be

the standard in effective treatment of onchocerciasis [8]. Oral administration of ivermectin rapidly kills microfilariae that are present in the human host; it does not kill the adult worms, but it does reduce their reproductive rate for several months [3, 13]. In a study spanning 1987-1991, analysis of data from five consecutive annual treatments with ivermectin showed reduced microfilariae production after each treatment. The microfilariae production did gradually increase over a 10 month period, reaching a plateau that was around 32% lower than pre-treatment values [13]. In spite of this, the distribution of ivermectin in sub-Saharan Africa remains a challenge due to many factors, including the more pronounced itching caused by the increase in the number of microfilariae deaths brought on by treatment with ivermectin and the restriction that ivermectin is only approved for children and adults over the age of 5 who are neither pregnant nor chronically ill [15].

In the African Programme for Onchocerciasis Control's (APOC) progress report for 2014-2015, 22 of 26 endemic countries (from a total of 28 endemic countries) reported treatment data showing 65.3% global coverage, with 11 of the 22 endemic countries achieving less than 65% coverage [1]. There are an estimated 125 million people worldwide who are at risk for onchocerciasis, with the vast majority in Africa [19].

A variety of models have been developed to study onchocerciasis. Most recent work has been done using complex simulation software packages ONCHOSIM [14] or SIMON [5] that include all immunological and epidemiological processes believed to be relevant. These can be used to make predictions for specific locations, but the value of the predictions are limited by the difficulty of estimating parameter values. Although predictions from ONCHOSIM closely fit the data for the first five years of ivermectin treatment, the results from the subsequent twelve years of treatment showed the predictions from ONCHOSIM to be overly optimistic with regard to the feasibility of eradication [4]. Even if good data is available, simulation models cannot easily be used to characterize the overall effect of each parameter on model behavior, so it is difficult to use them to obtain conclusions of broad applicability.

Another model in common use is EpiOncho [18], a population-based deterministic model that incorporates immunological elements, such as the mean number of female adult worms per host, the mean number of microfilaria per milligram of skin, and the mean number of larvae per vector that are at the stage of development to be transmitted to a human host, with epidemiological elements. The complexity of the model again makes it difficult to draw broad conclusions that do not depend strongly on estimated parameter values.

As an alternative to complex models, one can construct simpler models that incorporate only the most important biological features of a setting or focus on some aspects of a setting while oversimplifying others. For example, Basáñez and Boussinesq [2] developed an immunological model that focuses on the population dynamics of *O. volvulus* within the human hosts, while Remme et al [16] developed a model that focuses on the force of infection.

Because disease eradication depends on epidemiological factors rather than immunological factors, there should be some value to developing a purely epidemiological deterministic model for onchocerciasis; however, there does not seem to be any such model for onchocerciasis epidemiology more recent than 1982 [6]. One reason for this lack may be that the infectivity of human hosts to uninfected flies is not a simple parameter, but is dependent on the microfilarial load, which varies over time from almost nil immediately after ivermectin treatment to about 65% of

that in untreated humans by a year after treatment [13]. Nevertheless, it is reasonable to decouple the within-host dynamics from the epidemiological dynamics by assuming an “effective” infectivity factor for which the basic reproductive number of the model is roughly comparable to that of the actual disease.

Epidemiology models are classified according to the specific classes of individuals that need to be tracked (see [7] for an overview) and whether the diseases are infectious or vector-borne. In Section 2, we extend the SEIS (susceptible, exposed, infective, susceptible) model for a vector-borne disease to a nonstandard SEIPMS model that distinguishes three classes of infectives: standard infectives who do not participate in a health care system or are ineligible for ivermectin treatment (I), premedicated infectives who are participants in a health care system but not yet treated (P), and medicated infectives who have received ivermectin treatment (M). We show how this model can be approximated as an infectious disease model with nonlinear incidence. A linearized stability analysis provides a complete characterization of the equilibria as functions of a small number of model parameters. In Section 3 we present a more realistic model that assumes health care delivery occurs at discrete times rather than continuously and analyze that model by characterizing endemic periodic solutions, finding a uniqueness condition for the disease-free solution, and showing that the disease-free solution is stable whenever it is unique. Section 4 presents simulations that justify the use of an infectious disease model for onchocerciasis and compare the outcomes of annual and continuous delivery of health care.

2. A Continuous Model. An onchocerciasis model needs to have at least two classes for the black fly host, one for the uninfected flies (U) and one for the infected flies (V). In the absence of treatment, the human population needs to have at least three classes: susceptible (S), exposed (E), and infective (I). The exposed class for the human population is necessary because of the long incubation period for the disease. We omit an exposed class of flies because their incubation period is less than a week.

With treatment, it is necessary to use three infective classes for the humans: standard infectives who do not participate in a health care system or are ineligible for ivermectin treatment (I), premedicated infectives who are participants in a health care system but not yet treated (P), and medicated infectives who have received ivermectin treatment (M) (see Figure 2).

The model includes the following specific assumptions:

1. The human population N and fly population F are constant, as onchocerciasis is not fatal to either and does not inhibit reproduction. These parameters vary widely by region.
2. Human and black fly birth and death rates are proportional to the population numbers, with rate constants μ for humans and d for the flies, respectively. We take typical values to be $\mu = 0.02$ and $d = 12$ from lifespan estimates of 50 years for humans (appropriate for the regions where the disease is most prevalent) and 1 month for the flies.
3. The infection rate of humans is proportional to the susceptible population S and the (infected) vector population V , with proportionality constant β . The rate constant β depends on the rate at which humans are bitten by flies and the probability that a given bite transmits the larvae. This value is hard to measure directly.

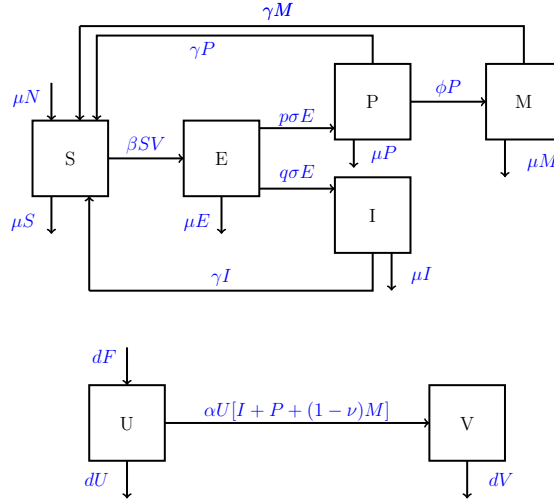

FIGURE 2. The SEIPMS-UV epidemiological model.

4. Exposed individuals become infectious at a rate proportional to their number, with rate constant σ that is independent of participation in the health care system. The incubation period for onchocerciasis is about one year, because the larvae that infect humans must develop into a second larval stage and mature into adult worms before the mature adults begin to produce the microfilaria that infect the flies. Hence, a typical value is $\sigma = 1$.
5. Ivermectin treatment is available to a fraction p of the population, limited by restrictions on who can receive the medication and limited health care coverage and participation. Thus, the rates of progress from class E to classes P and I are $p\sigma$ and $q\sigma$, respectively, where $q = 1 - p$. A typical value is $p = 0.65$ [1]; however, this quantity could perhaps be increased through interventions.
6. Individuals move from the premedicated class P to the medicated class M at a rate proportional to the population, with rate constant ϕ taken as the reciprocal of the mean time between the first production of microfilaria and the onset of treatment. With typical health care delivery rates of once per year, a typical value is $\phi = 2$.
7. The infection rate of the fly vector is proportional to the product of the uninfected fly population $F - V$ and the effective population of infective humans (W), with proportionality constant α . Like β , the factor α is hard to measure directly.
8. The effective population of infective humans is $W = I + P + (1 - \nu)M$, where ν is the relative decrease in infectivity of a medicated host compared to an untreated host. In reality, ν is 1 shortly after treatment and gradually falls to about 0.35 [13]. For our model that neglects population dynamics within the host, we take ν to be constant, with a typical value of 0.6 to 0.8.
9. The *O. volvulus* life cycle cannot be completed in the absence of the fly host; hence, there is a possibility for patients to be cured of the disease through the deaths of all the adult worms. Adult worms have an average life span of approximately 12 years, independent of the treatment, so we use a common rate constant γ for the progress of all three infective classes to the S class,

with typical value $\gamma = 0.08$. This assumption ignores the possibility of having the infection reintroduced into human hosts who are already infected, which would restart the clock for clearance of the disease; hence, our model will overestimate the clearance rate.

These assumptions yield a model consisting of differential equations for E , I , $H = P + M$ (the population of infected individuals who are currently or will eventually be treated), M , and V , along with an algebraic equation for S :

$$\frac{dE}{dT} = \beta SV - (\sigma + \mu)E, \quad (1)$$

$$\frac{dI}{dT} = q\sigma E - (\gamma + \mu)I, \quad (2)$$

$$\frac{dH}{dT} = p\sigma E - (\gamma + \mu)H, \quad (3)$$

$$\frac{dM}{dT} = \phi H - (\phi + \gamma + \mu)M, \quad (4)$$

$$\frac{dV}{dT} = \alpha(F - V)W - dV, \quad (5)$$

$$S + E + I + H = N, \quad W = I + H - \nu M. \quad (6)$$

where we have used T for time in order to reserve t for dimensionless time. Note that differential equations are not needed for S and U because the populations N and F are constant.

2.1. Nondimensionalization and Simplification. We define six dimensionless parameters:

$$\delta = \frac{\gamma + \mu}{d}, \quad \epsilon = \frac{\mu}{\sigma}, \quad \theta = \frac{\gamma + \mu}{\phi}, \quad \eta = \frac{\gamma + \mu}{\sigma + \mu}, \quad a = \frac{\alpha N}{d}, \quad b = \frac{\beta F}{\gamma + \mu}. \quad (7)$$

The parameters δ , ϵ , θ , and η are chosen for convenience from among many possible parameters representing ratios of time scales; specifically, δ , θ , and η represent (approximately) the expected times for fly lifespan, treatment, and larval development relative to the adult worm lifespan, respectively; while ϵ represents the ratio of larva development time to human lifespan. The parameters a and b represent the expected number of transmissions from a fully-infective human to a susceptible fly and from an infective fly to a susceptible human, respectively.

The natural scale for all human population groups is the total population N ; however, the analysis benefits from scaling groups according to the sizes needed for equilibrium. In particular, the I and H equations establish that $E = O(\eta N)$, so ηN is a better scale for E than is N . We choose the expected time in the infective class for the time scale, so $t = (\gamma + \mu)T$. With our typical parameter values, one unit of dimensionless time represents about 10 years.

With the substitutions

$$S = Ns, \quad E = \frac{\gamma + \mu}{\sigma}Nx, \quad I = Ni, \quad H = Nh, \quad M = Nm, \quad V = Fv, \quad t = (\gamma + \mu)T, \quad (8)$$

the model becomes

$$\eta \frac{dx}{dt} = bsv - x, \tag{9}$$

$$\frac{di}{dt} = qx - i, \tag{10}$$

$$\frac{dh}{dt} = px - h, \tag{11}$$

$$\theta \frac{dm}{dt} = h - (1 + \theta)m, \tag{12}$$

$$\delta \frac{dv}{dt} = aw(1 - v) - v, \tag{13}$$

$$s + i + h + \eta(1 + \epsilon)x = 1, \quad w = i + h - \nu m. \tag{14}$$

Using the estimates $\mu = 0.02$, $d = 12$, $\gamma = 0.08$, $\sigma = 1$, and $\phi = 2$, all in inverse years, we can estimate the first four dimensionless parameters as

$$\delta \approx 0.008, \quad \epsilon \approx 0.02, \quad \theta \approx 0.05, \quad \eta \approx 0.1. \tag{15}$$

The parameters a and b are order 1 and can be estimated from known endemic fractions of infected humans and flies in the absence of ivermectin treatment (see Section 4). We will examine asymptotic limits as ϵ , θ , and η go to 0 as needed. For now, we assume

$$\delta \rightarrow 0, \tag{16}$$

which makes the vector equation (13) quasi-steady, yielding the algebraic equation

$$v = \frac{aw}{1 + aw}. \tag{17}$$

The final model, consisting of differential equations (9)–(12) along with algebraic equations (14) and (17), is an SEIPMS infectious disease model with nonlinear incidence.

The error in taking $\delta \rightarrow 0$ is significant only on a very short time scale. Simulation results in Figure 3 verify this claim in the case where a small number of infective humans seed a region where the disease was previously absent. The plot of Figure 3a includes both the solution of the full model ((9)–(14), solid curve) and the simplified model with the quasi-steady approximation for the vector equation ((17) instead of (13), dash-dot); there is no visible difference. In both cases, the numbers of infective humans and flies gradually increase over a five-year period to their stable no-treatment values, with the greatest increase coming between 1 and 3 years. To highlight the actual difference, Figure 3b shows the solution on a much shorter time scale. The infective vector population rises from 0 to 0.01 (1% of the total fly population) in the first two days, while the quasi-steady approximation jumps to that level instantly. This is the extent of the error caused by the approximation.

2.2. Equilibria and Stability. The system (9)–(12), (14), and (17) always has a disease-free equilibrium in which $s = 1$ and all other variables are 0. Any endemic disease equilibria must satisfy the equations

$$i = qx, \quad h = px, \quad m = \frac{p}{1 + \theta}x, \quad s = 1 - (1 + \zeta)x, \quad w = \rho x, \tag{18}$$

where

$$\rho \equiv 1 - \frac{\nu p}{1 + \theta}, \quad \zeta = \eta(1 + \epsilon), \tag{19}$$

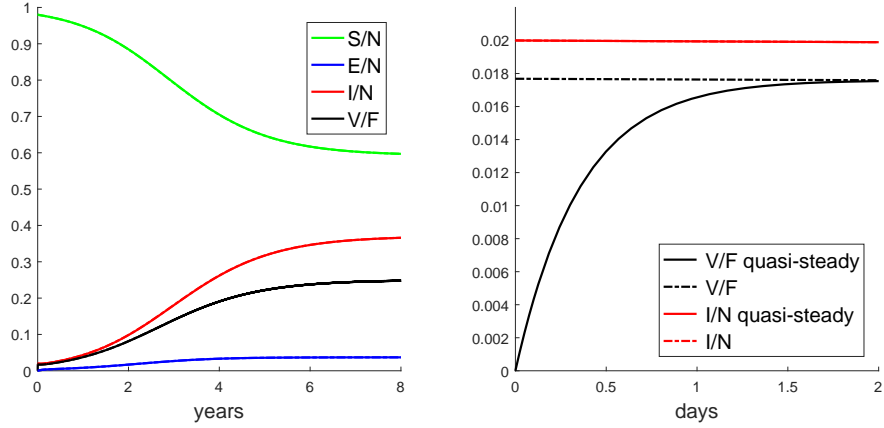

FIGURE 3. Simulation of the introduction of a small population of human infectives into a previously unexposed population, showing E/N , V/F , S/N , and I/N (from the bottom up at 5 years), using $a = 0.9$, $b = 2.5$, $\eta = 0.1$, $\epsilon = 0$, $p = 0$, with solid for $\delta = 0.001$ and dash-dot for $\delta = 0$.

which follow immediately from (10)–(12) and (14). This leaves the algebraic system

$$bsv = x, \quad v = \frac{\rho ax}{1 + \rho ax} \quad (20)$$

for v and x . Assuming $v, x > 0$, these equations can be rewritten as

$$v^{-1} = bx^{-1} - (1 + \zeta)b, \quad (21)$$

$$v^{-1} = (\rho a)^{-1}x^{-1} + 1, \quad (22)$$

and then elimination of v yields the result

$$x = \frac{1 - R_0^{-1}}{1 + b^{-1} + (1 + \epsilon)\eta}, \quad \text{provided } R_0 > 1, \quad (23)$$

where

$$R_0 = \rho ab \quad (24)$$

is the basic reproductive number.

We can interpret R_0 as the product of the number of secondary human infections per infective fly (b) and the number of secondary fly infections per infected human (ρa), where $\rho < 1$ is a weighted average of the relative infectivity for the classes I , P , and M as compared to the infectivity of class I .

The stability of the equilibria is determined by the Jacobian matrix, which is

$$J = \begin{bmatrix} -\eta^{-1}Q_1 & \eta^{-1}Q_3 & \eta^{-1}Q_3 & -\eta^{-1}\nu Q_2 \\ q & -1 & 0 & 0 \\ p & 0 & -1 & 0 \\ 0 & 0 & \theta^{-1} & -\theta^{-1} - 1 \end{bmatrix},$$

where

$$Q_1 = 1 + \eta bv, \quad Q_2 = bs \frac{dv}{dw} = \frac{abs}{(1 + aw)^2}, \quad Q_3 = Q_2 - bv. \quad (25)$$

The characteristic polynomial can then be written as

$$P_4(\lambda) = (\lambda + 1)P_3(\lambda) \quad (26)$$

where

$$P_3(\lambda) = (\lambda + \eta^{-1}Q_1)(\lambda + \theta^{-1} + 1)(\lambda + 1) - \eta^{-1}Q_3(\lambda + \theta^{-1} + 1) + \eta^{-1}\theta^{-1}\nu pQ_2. \quad (27)$$

The stability of the equilibria can then be determined from P_3 by the Routh-Hurwitz conditions $c_1 > 0$, $c_3 > 0$, and $c_1c_2 > c_3$, where c_j is the coefficient of λ^{3-j} [12]. Here

$$c_1 = (\theta^{-1} + 1) + (\eta^{-1}Q_1 + 1) > 0,$$

$$\begin{aligned} c_2 &= \eta^{-1}(Q_1 + bv) + [(\theta^{-1} + 1)(\eta^{-1}Q_1 + 1) - \eta^{-1}Q_2] \\ &> \eta^{-1}(Q_1 + bv) + \eta^{-1}(\theta^{-1} + 1)Q_1 - \eta^{-1}Q_2, \end{aligned}$$

$$c_3 = \eta^{-1}(\theta^{-1} + 1)(Q_1 + bv - \rho Q_2),$$

and

$$c_1c_2 > \eta^{-1}(\theta^{-1} + 1)(Q_1 + bv) + c_1\eta^{-1}[(\theta^{-1} + 1)Q_1 - Q_2].$$

These calculations leave a primary stability criterion (from $c_3 > 0$) of

$$\rho Q_2 < Q_1 + bv. \quad (28)$$

Given the bound $\rho(\theta^{-1} + 1) = 1 + \theta^{-1}(1 - \nu p) > 1$ from (19), the inequality

$$\rho Q_2 < Q_1 \quad (29)$$

is sufficient for the other remaining criterion (from $c_1c_2 > c_3$).

The disease-free equilibrium has

$$Q_1 = 1, \quad Q_2 = ab, \quad v = 0,$$

so both stability criteria become

$$R_0 = \rho ab < 1,$$

confirming that the disease-free equilibrium is stable when $R_0 < 1$ and unstable when $R_0 > 1$. The endemic disease equilibrium has

$$\rho Q_2 = \frac{\rho abs}{(1 + aw)^2} = \frac{\rho a}{(1 + aw)^2} \frac{x}{v} = \frac{1}{1 + aw} < 1 < Q_1,$$

so both criteria are always satisfied, provided that the existence requirement $R_0 > 1$ is met.

Proposition 1 summarizes the results.

Proposition 1.

The SEIPMS model given by (9)–(12), (14), (17) has

1. a disease-free equilibrium that is stable whenever $R_0 < 1$ (24), and
2. a stable endemic disease equilibrium given by (23) and (18) whenever $R_0 > 1$.

3. A Pulsed Model. The general pulsed model follows from two changes to the SEIPMS model of Section 2:

1. Set $\phi = 0$ because delivery of health care occurs only at fixed intervals;
2. Introduce a jump condition at times $n\tau$, where τ is the scaled treatment interval (typically 0.1 or 0.05, corresponding to treatment intervals of 1 year or 6 months with a time scale of 10 years). At these points in time, all individuals in the premedicated class become medicated, which means $m = h$.

Thus, the model (using the $\delta \rightarrow 0$ and $\epsilon = 0$ approximations) is

$$\eta \frac{dx}{dt} = bsv - x, \quad x^+ = x^- \text{ at } t = n\tau, \quad (30)$$

$$\frac{di}{dt} = qx - i, \quad i^+ = i^- \text{ at } t = n\tau, \quad (31)$$

$$\frac{dh}{dt} = px - h, \quad h^+ = h^- \text{ at } t = n\tau, \quad (32)$$

$$\frac{dm}{dt} = -m, \quad m^+ = h^- \text{ at } t = n\tau, \quad (33)$$

$$s = 1 - i - h - \eta x, \quad v = \frac{aw}{1 + aw}, \quad w = i + h - \nu m. \quad (34)$$

The system can be simplified somewhat by introducing variables y , z , and r to replace h , i , and m and rescaling time to match the treatment interval:

$$y = p^{-1}h, \quad z = i - qy, \quad r = p^{-1}m, \quad t^* = \frac{t}{\tau}, \quad \xi = \frac{\tau}{\eta}. \quad (35)$$

The problem for z is then

$$\frac{dz}{dt^*} = -\tau z, \quad z^+ = z^- \text{ at } t^* = n,$$

which can be solved immediately, reducing the system to

$$\frac{dx}{dt^*} = \xi(bsv - x), \quad x^+ = x^- \text{ at } t^* = n, \quad (36)$$

$$\frac{dy}{dt^*} = \tau(x - y), \quad y^+ = y^- \text{ at } t^* = n, \quad (37)$$

$$\frac{dr}{dt^*} = -\tau r, \quad r^+ = y^- \text{ at } t^* = n, \quad (38)$$

$$s = 1 - y - z - \eta x, \quad v = \frac{aw}{1 + aw}, \quad w = y + z - \nu pr, \quad z = z(0)e^{-\tau t^*}. \quad (39)$$

3.1. Periodic Solutions. Periodic solutions are defined by the differential equations of (36–38) along with the periodic conditions

$$x(0) = x(1), \quad y(0) = y(1), \quad r(0) = y(1) \quad (40)$$

and the auxiliary equations of (39). Clearly any periodic solution must have $z = 0$, and we can solve the r equation analytically; thus, we can recast the problem as that of finding initial conditions (x_i, y_i) such that the solution of the system defined by

$$\frac{dx}{dt} = \xi[bsv - x], \quad x(0) = x_i, \quad (41)$$

$$\frac{dy}{dt} = \tau(x - y), \quad y(0) = y_i, \quad (42)$$

where

$$s = 1 - y, \quad w = y - y_i \nu p e^{-\tau t}, \quad v = \frac{w}{a^{-1} + w}, \quad (43)$$

satisfies the periodicity conditions

$$x(1) = x(0), \quad y(1) = y(0). \quad (44)$$

Obviously there is a disease-free periodic solution with $x_0 = y_0 = 0$. Numerical solutions can in principle be found by solving (44); in practice, this system is difficult to work with because the presence of the small parameter τ in (42) makes y very nearly constant. As an alternative, we can derive another periodicity condition by combining (41) and (42) into a single equation

$$\xi^{-1} \frac{dx}{dt} + \tau^{-1} \frac{dy}{dt} = bsv - y;$$

integration over the interval $[0, 1]$ then yields the condition

$$\int_0^1 bsv \, dt = \int_0^1 y \, dt. \quad (45)$$

Our numerical scheme implements this condition by adding initial value problem components

$$\frac{dF}{dt} = bsv, \quad F(0) = 0; \quad \frac{dY}{dt} = y, \quad Y(0) = 0; \quad (46)$$

whence we can compute the correct initial conditions (x_i, y_i) from

$$x(1) = x(0), \quad F(1) = Y(1). \quad (47)$$

Figure 4 shows some periodic solutions using typical parameter values. The variation over the treatment interval is seen primarily in the exposed populations and not the infective population. The principal driver of this behavior is the sudden drop in infectivity from human to fly each time treatment occurs. This creates a noticeable decrease in the infected fly population, which decreases the rate at which susceptible humans become infected; meanwhile, the rate at which exposed humans become infective changes only slightly during the period. The result is a decline in the exposed population in the first portion of the treatment interval. The subsequent rise is due to the fact that individuals who become infective during the interval between treatments are not medicated and hence more infective to the flies.

3.2. Asymptotic Approximation. It is also possible to compute asymptotic approximations for periodic solutions by using the asymptotic assumptions

$$x(t; \tau) = x_0 + \tau x_1(t) + O(\tau^2), \quad y(t; \tau) = y_0 + \tau y_1 + O(\tau^2). \quad (48)$$

It is not immediately obvious that x_0 and y_1 are constants. The first of these follows from

$$x'_0(t) = \xi b s_0 v_0 - \xi x_0(t), \quad s_0 = 1 - y_0, \quad v_0 = \frac{(1 - \nu p) y_0}{a^{-1} + (1 - \nu p) y_0};$$

because periodicity along with s_0 and v_0 being constant results in the solution

$$x_0 = b s_0 v_0.$$

The condition $F(1) = Y(1)$ along with this last result means

$$y'_1 = x_0 - y_0 = b s_0 v_0 - b s_0 v_0 = 0,$$

establishing that y_1 is also constant. The solution of $b s_0 v_0 = y_0$ yields the results

$$w_0 = \frac{b(1 - \nu p) - a^{-1}}{b + 1}, \quad y_0 = \frac{w_0}{1 - \nu p}, \quad s_0 = 1 - y_0, \quad v_0 = \frac{w_0}{a^{-1} + w_0}. \quad (49)$$

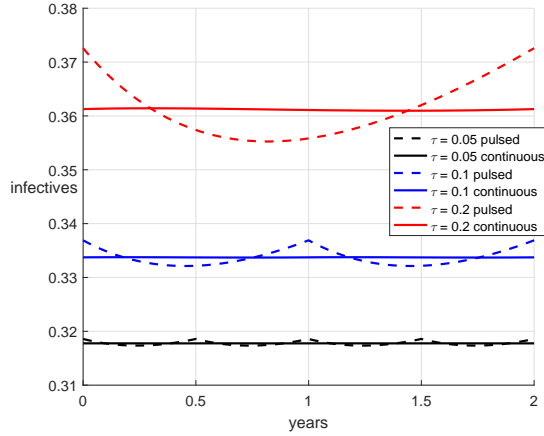

FIGURE 4. Periodic solutions for the exposed (x , dashed) and total infective ($h + i = x + y$, solid) classes, with treatment intervals of 2 years (top), 1 year (middle), and 6 months (bottom), using $a = 1$, $b = 4$, $\eta = 0.1$, $\epsilon = 0$, $\nu p = 0.6$.

Substitution of (48b) and $bs_0v_0 = y_0$ into (47b), along with the additional definitions

$$K = \frac{1 - v_0}{a^{-1} + w_0}, \quad f_{10} = b[(1 - \nu p)s_0K - v_0], \quad f_{11} = b\nu p y_0 s_0 K, \quad (50)$$

yield the result

$$y_1 = \frac{f_{11}}{2(1 - f_{10})}. \quad (51)$$

The solution of $x'_1 = \xi(bs_1v_1 - x_1)$ with periodicity in x_1 yields the final result

$$x_1(t) = f_{10}y_1 - \frac{f_{11}}{\xi} + f_{11}t + \frac{f_{11}e^{-\xi t}}{1 - e^{-\xi}}. \quad (52)$$

Details of these calculations appear in the Appendix.

3.3. A Necessary Condition for an Endemic Disease Equilibrium. If we begin with a set of parameters that yields an endemic disease equilibrium and gradually make the parameters less favorable, the solutions of the fixed point equations (44) gradually converge to $(x_0, y_0) = (0, 0)$. Hence, the critical case can be thought of as corresponding to the limit of the periodic solution problem as $y_0 \rightarrow 0$ with $x_0 = O(y_0)$. We can identify the bifurcation hypersurface by assuming

$$(x, y, x_0, x_1, y_1) = (y_0X, y_0Y, y_0X_0, y_0X_1, y_0Y_1) \quad (53)$$

in (41–44) and taking the asymptotic limit $y_0 \rightarrow 0$ resulting in the problem

$$\frac{dX}{dt^*} = -\xi X + \xi abY - \xi ab\nu p e^{-\tau t^*}, \quad X(1) = X(0), \quad (54)$$

$$\frac{dY}{dt^*} = \tau X - \tau Y, \quad Y(0) = Y(1) = 1. \quad (55)$$

With three boundary conditions for a system of two differential equations, this problem is overspecified and will have a solution only for a particular relationship among the parameters.

Letting $\mathbf{U}^T = [X \ Y]$, the system can be written in vector form as

$$\frac{d\mathbf{U}}{dt^*} = \begin{bmatrix} -\xi & \xi ab \\ \tau & -\tau \end{bmatrix} \mathbf{U} + \begin{bmatrix} \xi ab \\ 0 \end{bmatrix} \nu p e^{-\tau t^*}. \quad (56)$$

The eigenvalues of the matrix in (56) are given by

$$\lambda_{1,2} = \frac{-(\xi + \tau) \pm \sqrt{\xi^2 + (4ab - 2)\xi\tau + \tau^2}}{2}, \quad (57)$$

which are real for the case where the disease is endemic in the absence of treatment ($ab > 1$). Given a treatment interval that is much shorter than the lifespan of adult worms, we expect τ to be small ($\tau \approx 0.1$ for annual treatment); hence, we write the eigenvectors as

$$\mathbf{u}_1 = \begin{bmatrix} u_1 \\ 1 \end{bmatrix}, \quad \mathbf{u}_2 = \begin{bmatrix} u_2 \\ \tau \end{bmatrix} \quad \text{where} \quad u_1 = \frac{\lambda_1 + \tau}{\tau}, \quad u_2 = \lambda_2 + \tau. \quad (58)$$

With this notation, the solution of the system of differential equations is

$$X = c_1 u_1 e^{\lambda_1 t^*} + c_2 u_2 e^{\lambda_2 t^*}, \quad (59)$$

$$Y = c_1 e^{\lambda_1 t^*} + c_2 \tau e^{\lambda_2 t^*} + \nu p e^{-\tau t^*}. \quad (60)$$

The three boundary conditions yield a linear system for unknowns c_1 , c_2 , and νp , leading to the necessary condition (for existence of an endemic periodic solution)

$$\nu p < \frac{(\tau u_1 - u_2)(e^{\lambda_1} - 1)(1 - e^{\lambda_2})}{\tau u_1(e^{\lambda_1} - 1)(e^{-\tau} - e^{\lambda_2}) - u_2(e^{\lambda_1} - e^{-\tau})(1 - e^{\lambda_2})}. \quad (61)$$

Asymptotic expansion of this result (included in the Appendix) yields the approximate condition

$$\nu p < \left(1 - \frac{1}{ab}\right) \left(1 + \frac{\tau}{2}\right) + O(\tau^2), \quad (62)$$

which can be rearranged as

$$R_0 = ab \left(1 - \frac{\nu p}{1 + \tau/2} + O(\tau^2)\right) > 1. \quad (63)$$

The quantity on the left side of this inequality is the basic reproductive number for the continuous model ($\tau/2$ is the mean dimensionless time a newly infective person must wait for initial treatment, which was defined as θ in Section 2).

3.4. Stability of the Disease-Free Solution. Consider the case where there is a small perturbation to the disease-free solution owing to a small non-zero initial value $z(0) = z_0$, corresponding to the introduction of a small number of unmedicated infectives. We assume

$$(x, y, r, z) = (z_0 X, z_0 Y, z_0 R, z_0 Z)$$

and define sequences

$$X_n = X(n\tau), \quad Y_n = Y(n\tau), \quad Z_n = Z(n\tau) = e^{-n\tau}, \quad K_n = \nu p Y_n - Z_n,$$

along with a shifted time variable on the interval $n\tau < t^* < (n+1)\tau$:

$$t^* = n\tau + \hat{t}.$$

With the solution $R(\hat{t}) = Y_n e^{-\tau \hat{t}}$, we obtain a recursive definition of the sequences X_n and Y_n through the system

$$\frac{dX}{d\hat{t}} = -\xi X + \xi ab Y - \xi ab K_n e^{-\tau \hat{t}}, \quad X(0) = X_n, \quad X(1) = X_{n+1}, \quad (64)$$

$$\frac{dY}{d\hat{t}} = \tau X - \tau Y, \quad Y(0) = Y_n, \quad Y(1) = Y_{n+1}. \quad (65)$$

The eigenvalues and eigenvectors are again given by (57) and (58), leading to the solutions

$$X = c_1 u_1 e^{\lambda_1 \hat{t}} + c_2 u_2 e^{\lambda_2 \hat{t}}, \quad (66)$$

$$Y = c_1 e^{\lambda_1 \hat{t}} + c_2 \tau e^{\lambda_2 \hat{t}} + K_n e^{-\tau \hat{t}}, \quad (67)$$

where

$$c_1 = \frac{\tau X_n - (1 - \nu p) u_2 Y_n - u_2 Z_n}{\tau u_1 - u_2}, \quad c_2 = \frac{-X_n + (1 - \nu p) u_1 Y_n + u_1 Z_n}{\tau u_1 - u_2}. \quad (68)$$

Evaluating these solutions at $\hat{t} = 1$ yields a system of difference equations having the form

$$\mathbf{U}_{n+1} = A \mathbf{U}_n + Z_n \mathbf{b}.$$

Since $\lim_{n \rightarrow \infty} Z_n = 0$, the solution vector for this system decays to 0 if the eigenvalues of A have magnitude less than 1, which we can determine directly from the matrix entries

$$a_{11} = \frac{\tau u_1 e^{\lambda_1} - u_2 e^{\lambda_2}}{\tau u_1 - u_2}, \quad a_{12} = -(1 - \nu p) u_1 u_2 \frac{e^{\lambda_1} - e^{\lambda_2}}{\tau u_1 - u_2}, \quad (69)$$

$$a_{21} = \tau \frac{e^{\lambda_1} - e^{\lambda_2}}{\tau u_1 - u_2}, \quad a_{22} = (1 - \nu p) \frac{\tau u_1 e^{\lambda_2} - u_2 e^{\lambda_1}}{\tau u_1 - u_2} + \nu p e^{-\tau} \quad (70)$$

using the Jury conditions[9]

$$|\operatorname{tr} A| - 1 < \det A < 1. \quad (71)$$

With $\tau \rightarrow 0$, we can quickly see that

$$A \sim \begin{bmatrix} e^{-\xi} & O(1) \\ O(\tau) & 1 \end{bmatrix},$$

from which it is clear that the trace is positive and the determinant is less than 1; hence, the only condition that needs to be satisfied is

$$\operatorname{tr} A - 1 < \det A. \quad (72)$$

Computing and simplifying the trace and determinant yields the inequality

$$\begin{aligned} & (e^{\lambda_1} + e^{\lambda_2} - 1) + \nu p e^{-\tau} - \nu p \frac{\tau u_1 e^{\lambda_2} - u_2 e^{\lambda_1}}{\tau u_1 - u_2} \\ & < (1 - \nu p) e^{\lambda_1 + \lambda_2} + \nu p \frac{\tau u_1 e^{\lambda_1 - \tau} - u_2 e^{\lambda_2 - \tau}}{\tau u_1 - u_2}. \end{aligned}$$

Multiplying this inequality by the positive quantity $\tau u_1 - u_2$ and rearranging leads ultimately to the condition

$$\nu p > \frac{(\tau u_1 - u_2) (e^{\lambda_1} - 1) (1 - e^{\lambda_2})}{\tau u_1 (e^{\lambda_1} - 1) (e^{-\tau} - e^{\lambda_2}) - u_2 (e^{\lambda_1} - e^{-\tau}) (1 - e^{\lambda_2})}, \quad (73)$$

which is just the reverse of the inequality needed for existence of the endemic periodic solution.

Proposition 2 summarizes the results of the pulsed model.

Proposition 2.

In the limit $\eta \rightarrow 0$, the disease-free periodic solution is unique and stable whenever

$$\nu p > \frac{(\tau u_1 - u_2)(e^{\lambda_1} - 1)(1 - e^{\lambda_2})}{\tau u_1(e^{\lambda_1} - 1)(e^{-\tau} - e^{\lambda_2}) - u_2(e^{\lambda_1} - e^{-\tau})(1 - e^{\lambda_2})}.$$

When the inequality is reversed, the disease-free periodic solution is unstable and an endemic disease periodic solution can be found numerically by solving the algebraic equations (47) applied to the system (41), (42), (46). In the limit as $\tau \rightarrow 0$, the inequality reduces to

$$R_0 = ab \left(1 - \frac{\nu p}{1 + \tau/2} + O(\tau^2) \right) < 1.$$

4. Results and Discussion.

The value of asymptotics. Asymptotic approximation can sometimes simplify the analysis of a model without making an appreciable change in the results. This is most clearly seen in Figure 3, where the error caused by the quasi-steady assumption that changes the model from a vector-borne disease with linear incidence to an infectious disease with nonlinear incidence is only visible for the first two days of a disease introduction scenario. The duration of the period for which the initial transient is important depends primarily on the time scale of the differential equation being approximated. This time scale is just 30 days in the onchocerciasis model, so we should not expect a transient duration to be any longer than that. In this particular model, it turns out to be smaller yet. The extent of the imbalance between the initial conditions of the experiment and the equilibrium solution does not make much difference. For example, a similar experiment with double the initial load of human infectives shows a transient of the same duration.

Asymptotics also has a clear value in characterizing solutions, as for example in the analytical result for the periodic solutions of the pulsed model in the limit $\tau \rightarrow 0$. While the value in this case is modest, there are examples where asymptotic analysis can provide a detailed explanation of complex behavior (see [11] for an example).

Using an analytical model in lieu of a complex simulation. Modeling of onchocerciasis has generally been done using complex simulations such as ONCHOSIM and EpiOncho. One would expect that more detail would provide better results than a simplified model such as ours. This is true in theory, but in practice it is only true if the processes are very well understood and the parameter values are known to a modest degree of accuracy. Here there is ample reason for caution. The different simulation packages do not produce the same predictions, and some of these predictions have not borne out well in practice [4]. Simpler analytical models can be thought of as sacrificing precision for accuracy, insofar as they can be used to determine a range of reasonable results and the results are robust to changes in parameter values. Of course the accuracy of this range depends on the specific simplifications in the analytical model.

Our model has one major omission, which is that we assume that the expected duration of the onchocerciasis infection in humans is the same as the expected lifespan of the adult worm. This is not true if new onchocerca larvae can establish themselves in a human who is already infected from an earlier time. Reintroduction of larvae into an infective human would reset the 12-year timer for clearance of the

disease, resulting in a much smaller expected clearance rate. This omission makes our model more optimistic about the conditions needed for local eradication of the disease from any given population. Our results are not so much a projection of what will happen with a particular treatment plan as they are a best case scenario for what could happen with that plan.

Another simplification in our model of onchocerciasis is our assumption that the effect of treatment is to lower the infectivity of humans to flies by a fixed fraction ν . There is a considerable amount of literature showing that this is not the case; instead, the mean infectivity of humans drops to near 0 when the dose of ivermectin is administered but then rises to a level somewhat less than that of untreated patients but still significant. In theory, there should be a particular mean value of infectivity loss ν for any treatment protocol, but the best value for ν should depend on the frequency with which the medication is administered. This could be determined by the overall treatment interval (as represented by τ in the pulsed model and $\theta = \tau/2$ in the continuous model) if doses are only administered during the periodic visits by the medical community, but it could also be independent of the frequency of medical visits if it is possible to have permanent members of the population arrange for doses to be administered at any interval prescribed by the treatment plan. These considerations affect the choice of ν for investigations with the model, but the idea of using a fixed value of ν in lieu of a complex simulation is valid in any case.

Using the continuous model in lieu of the pulsed model. In practice, the treatment protocol for onchocerciasis leads to the pulsed model. As we would predict, the continuous model slightly underestimates the numbers of infectives compared to the pulsed model (see Figure 5), which increases the extent to which the model results are overly optimistic. However, the intervals between treatment events are short compared to the time required for a patient to be cleared of the disease ($\tau \ll 1$), which means that the results for the continuous model are only slightly better than those of the pulsed model. Certainly the difference between the continuous and pulsed models is small compared to the errors caused by uncertainty in parameter values. Given these considerations, we use the continuous model in the subsequent discussion of our model projections.

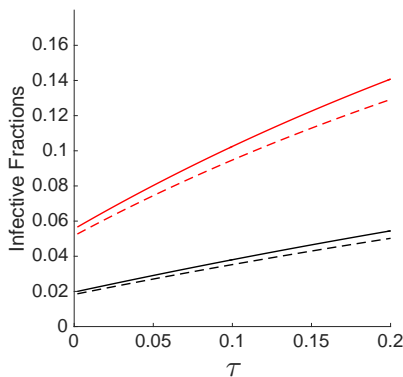

FIGURE 5. Time average infective populations, with $a = 0.9$, $b = 3$, $\eta = 0.1$, $\epsilon = 0$, $\nu p = 0.6$. Humans: top 2; Flies: bottom 2; Pulsed: solid; Continuous: dashed.

The prognosis for onchocerciasis treatment plans. Since the parameters a and b need to be inferred from the pre-treatment equilibrium, it is reasonable to cast the result for R_0 in terms of v_0 and i_0 instead of a and b . Noting that $i = x$ and $\rho = 1$ for the pre-treatment scenario, (20b) and (23) can be rewritten as

$$1 + ai_0 = \frac{1}{1 - v_0}, \quad 1 - \frac{1}{ab} = (1 + \eta + \epsilon\eta)i_0 + \frac{ai_0}{ab},$$

which we can combine together to get

$$ab = \frac{1}{(1 - v_0)[1 - (1 + \eta + \epsilon\eta)i_0]}.$$

The condition for a basic reproductive number $R_0 < 1$ is then

$$1 - \frac{\nu p}{1 + \theta} = \rho < \frac{1}{ab} = (1 - v_0)[1 - (1 + \eta + \epsilon\eta)i_0],$$

or

$$\nu p > (1 + \theta)\{1 - (1 - v_0)[1 - (1 + \eta + \epsilon\eta)i_0]\}. \quad (74)$$

Using estimated parameter values $i_0 = 0.46$ and $v_0 = 0.30$ [10], this means that eradication would require $\nu p \approx 0.69$. This is problematic, as the generally accepted treatment fraction is only $p = 0.65$ [1]. With an optimistic value of 0.9 for ν , achievable if treatment is more frequent than in the current protocol, a compliance rate higher than $p = 0.76$ would be required. This might be possible, but it would be difficult to achieve since there are people who cannot be given ivermectin treatment, such as pregnant women and children under the age of 5.

Even if R_0 can be brought below 1, the eradication dynamics is unacceptably slow. Figure 6 shows the results of simulations using $a = 0.9$ with optimistic and pessimistic values for b and νp . The combination of $a = 0.9$ and $b = 3$ yields a pre-treatment equilibrium of 44% human infectivity and 28% fly infectivity, which is not quite as much as the reported values given above. The lowest curve in each plot is for the optimistic choices $b = 2$ and $\nu p = 0.8$, corresponding to $R_0 = 0.43$. It takes about 60 years in this scenario for the infective populations of humans and flies to be decreased to 10% of their initial values. These disappointing results are due to two key factors:

1. Ivermectin does not kill adult worms, so the expected value of the time needed to eradicate the disease from an individual human host is still half the lifespan of the adult worms, which is about 6 years.
2. Even with optimistic projections for microfilaria suppression and fraction of humans who get treated, the expected transmission rate from an individual human to the black fly population is still 20% of the untreated value.

While our model is overly simple, it should be able to provide an overestimate of the efficacy of onchocerciasis treatment simply by choosing an optimistic value of νp ; thus, the results strongly suggest that the current eradication plan is inadequate. The problem cannot be fixed simply by improving parameter values such as the treatment fraction. The more significant reason for the poor results is that ivermectin targets the parasite at the least critical point in its life cycle. From a mathematical point of view, we should apply a treatment plan that targets the adult worms because this would shorten the expected value of the longest time scale. While this might not have a larger effect on the basic reproductive number, it would speed up the approach to the disease-free equilibrium by changing the time scale of that approach.

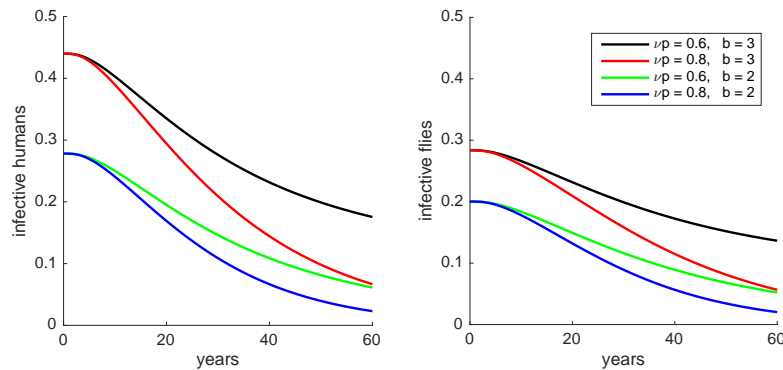

FIGURE 6. Simulations of various treatment scenarios, with $a = 0.9$, $\eta = 0.1$, $\epsilon = 0$.

REFERENCES

- [1] *African Programme for Onchocerciasis Control: progress report, 2014-2015. Relevé Épidémiologique Hebdomadaire / Section D'hygiène Du Secrétariat De La Société Des Nations = Weekly Epidemiological Record / Health Section Of The Secretariat Of The League Of Nations*, **90**(2015), 661–674.
- [2] M. Basáñez and M. Boussinesq, Population biology of human onchocerciasis, *Philosophical Transactions: Biological Sciences*, **1384**(1999), 809–826.
- [3] L.E. Coffeng, W.A. Stolk, H.G.M. Zouré, J.L. Veerman, and K.B. Agblewou, African programme for onchocerciasis control 1995–2015: model-estimated health impact and cost, *PLoS Neglected Tropical Diseases*, **7**(2013): e2032.
- [4] Y. Dadzie, M. Neira, and D. Hopkins Final report of the Conference on the eradicability of Onchocerciasis, *Filaria Journal*(2003), 22–134.
- [5] J.B. Davies, Description of a computer model of forest onchocerciasis transmission and its application to field scenarios of vector control and chemotherapy, *Ann Trop Med Parasitol* **87**(1993), 41–63.
- [6] K. Dietz, The population dynamics of onchocerciasis, in *Population Dynamics of Infectious Diseases* (ed. R.M. Anderson), Chapman and Hall, (1982), 209–241.
- [7] H.W. Hethcote, The mathematics of infectious diseases, *SIAM Review*, **42** (2000), 599–653.
- [8] A. Hopkins and B.A. Boatin, Onchocerciasis, in *Water and Sanitation-Related Diseases and the Environment: Challenges, Interventions, and Preventive Measures* (ed J.M.H. Selendy), John Wiley & Sons, Inc, (2011), 133–149.
- [9] E.I. Jury, A simplified stability criterion for linear discrete systems, *Proceedings of the IRE* **50**(1962), 1493–1500.
- [10] M.N. Katarbarwa, A. Eyamba, P. Nwane, P. Enyong, S. Yaya, J. Baldagai, T.K. Madi, A. Yougouda, G.O. Andze, and F.O. Richards, Seventeen years of annual distribution of ivermectin has not interrupted Onchocerciasis transmission in North Region, Cameroon, *The American Journal Of Tropical Medicine And Hygiene* [serial online], December 2011 **85**(2011), 1041-1049.
- [11] G. Ledder, Forest defoliation scenarios, *Math Biosci. Eng.*, **4**(2007), 15–28.
- [12] G. Ledder, *Mathematics for the Life Sciences: Calculus, Modeling, Probability, and Dynamical Systems*, Springer-Verlag, 2013.
- [13] A.P. Plaisier, E.S. Alley, B.A. Boatin, G.J. van Oortmarssen, and H. Remme, Irreversible effects of ivermectin on adult parasites in onchocerciasis patients in the Onchocerciasis Control Programme in West Africa, *Journal of Infectious Disease* **172**(1995), 204–210.
- [14] A.P. Plaisier, G.J. van Oortmarssen, J.D.F. Habbema, J. Remme, and E.S. Alley ONCHOSIM: a model and computer simulation program for the transmission and control of onchocerciasis, *Comput Methods Programs Biomed.* **31**(1990), 43–56.
- [15] B. Ranganathan, Onchocerciasis: an overview, *Amrita Journal of Medicine*, **8**(2012), 1–9.

- [16] J. Remme, O. Ba, K.Y. Dadzie, and M. Karam, A force-of-infection model for onchocerciasis and its applications in the epidemiological evaluation of the Onchocerciasis Control Programme in the Volta River basin area, *Bulletin of the World Health Organization*, **64**(1986), 667–681.
- [17] F. Richards, N. Rizzo, and A. Domínguez, One hundred years after its discovery in Guatemala by Rodolfo Robles, *Onchocerca volvulus* transmission has been eliminated from the Central Endemic Zone, *The American Journal Of Tropical Medicine And Hygiene* [serial online]. December 2015 **93**(2015), 1295–1304.
- [18] H.C. Turner, W. Walker, T.S. Churcher, and M. Basáñez, Modeling the impact of ivermectin on river blindness and its burden of morbidity and mortality in African Savannah: EpiOncho projections, *Parasites and Vectors*, **7**(2014), 241–255.
- [19] F. Weldegebreal, G. Medhin, Z. Weldegebriel, and M. Legesse, Knowledge, attitude and practice of community drug distributors' about onchocerciasis and community directed treatment with ivermectin in Quara district, North Western Ethiopia, *BMC Research Notes*, **9**(2016), 1–8.

. **Appendix: Asymptotics for the Pulsed Model.**

A.1. **Periodic solutions as $\tau \rightarrow 0$.** This subsection shows the calculations necessary to obtain the approximations (51) and (52),

$$y_1 = \frac{f_{11}}{2(1-f_{10})}, \quad x_1(t) = f_{10}y_1 - \frac{f_{11}}{\xi} + f_{11}t + \frac{f_{11}e^{-\xi t}}{1-e^{-\xi}},$$

where

$$K = \frac{1-v_0}{a^{-1}+w_0}, \quad f_{10} = b[(1-\nu p)s_0K - v_0], \quad f_{11} = \nu p y_0 s_0 K.$$

We begin by defining $f = bsv$ and assuming the asymptotic expansions

$$\begin{aligned} w &\sim w_0 + \tau w_1 w_1 = w_{10}y_1 + w_{11}t \\ v &\sim v_0 + \tau v_1, \quad v_1 = v_{10}y_1 + v_{11}t \\ f &\sim f_0 + \tau f_1, \quad f_1 = f_{10}y_1 + f_{11}t \end{aligned}$$

The periodicity condition (47b) reduces to $\int_0^1 f_1(t) dt = y_1$, which immediately yields (51). Similarly, the result given for x_1 satisfies the differential equation $x_1' = \xi(f_1 - x_1)$ along with the periodicity condition $x_1(1) = x_1(0)$. It remains to show that the formulas for f_{10} and f_{11} are correct. Expanding w yields

$$w = y - \nu p y_i e^{-\tau t} \sim y[1 - \nu p(1 - \tau t)], \quad (\text{A})$$

whence

$$w_{10} = 1 - \nu p, \quad w_{11} = \nu p y_0. \quad (\text{B})$$

The equation $v = w/(a^{-1} + w)$ can be written as

$$(v_0 + \tau v_1)(a^{-1} + w_0 + \tau w_1) = w_0 + \tau w_1,$$

from which we eventually obtain

$$v_{10} = (1 - \nu p)K, \quad v_{11} = \nu p y_0 K. \quad (\text{C})$$

The results for f_{10} and f_{11} then follow from

$$f \sim b(s_0 - \tau y_1)[v_0 + \tau(v_{10}y_1 + v_{11}t)]. \quad (\text{D})$$

A.2. **Existence condition for a nontrivial periodic solution.** This subsection shows the calculations necessary to obtain the approximation (62)

$$\nu p < \left(1 - \frac{1}{ab}\right) \left(1 + \frac{\tau}{2}\right) + O(\tau^2),$$

from the original result (61)

$$\nu p < \frac{(\tau u_1 - u_2)(e^{\lambda_1} - 1)(1 - e^{\lambda_2})}{\tau u_1(e^{\lambda_1} - 1)(e^{-\tau} - e^{\lambda_2}) - u_2(e^{\lambda_1} - e^{-\tau})(1 - e^{\lambda_2})}.$$

1. We begin by rewriting the original result as

$$P = \frac{(e^{\lambda_1} - 1) \left(1 - \frac{\tau u_1}{u_2}\right)}{(e^{\lambda_1} - e^{-\tau}) - \frac{\tau u_1}{u_2} (e^{\lambda_1} - 1) \frac{e^{-\tau} - e^{\lambda_2}}{1 - e^{\lambda_2}}} = \frac{e^{\lambda_1} - 1}{e^{\lambda_1} - e^{-\tau}} \cdot \frac{1 - \frac{\tau u_1}{u_2}}{1 - \frac{\tau u_1}{u_2} \cdot \frac{e^{\lambda_1} - 1}{e^{\lambda_1} - e^{-\tau}} \cdot \frac{e^{-\tau} - e^{\lambda_2}}{1 - e^{\lambda_2}}}. \quad (\text{E})$$

2. The eigenvalue $\lambda_2 \sim -\xi = O(1)$ as $\tau \rightarrow 0$; hence, the last factor in the denominator can be expanded as

$$\frac{e^{-\tau} - e^{\lambda_2}}{1 - e^{\lambda_2}} \sim 1 + O(\tau)$$

and $u_2 = \lambda_2 + \tau \sim -\xi$. We then have

$$P \sim \frac{e^{\lambda_1} - 1}{e^{\lambda_1} - e^{-\tau}} \cdot \frac{1 + \xi^{-1}\tau u_1 + O(\tau^2)}{1 + \xi^{-1}\tau u_1 \cdot \frac{e^{\lambda_1} - 1}{e^{\lambda_1} - e^{-\tau}} + O(\tau^2)}. \quad (\text{F})$$

3. The eigenvalue λ_1 is $O(\tau)$ as $\tau \rightarrow 0$; hence, the other ratio of exponential functions can be expanded as

$$\begin{aligned} \frac{e^{\lambda_1} - 1}{e^{\lambda_1} - e^{-\tau}} &\sim \frac{\lambda_1 + \frac{1}{2}\lambda_1^2 + O(\tau^3)}{(\lambda_1 + \frac{1}{2}\lambda_1^2) - (-\tau + \frac{1}{2}\tau^2)} = \frac{\lambda_1 + \frac{1}{2}\lambda_1^2 + O(\tau^3)}{(\lambda_1 + \tau) + \frac{1}{2}(\lambda_1^2 - \tau^2)} \\ &= \frac{\lambda_1}{\lambda_1 + \tau} \cdot \frac{1 + \frac{1}{2}\lambda_1 + O(\tau^2)}{1 + \frac{1}{2}(\lambda_1 - \tau)} \sim \frac{\lambda_1}{\lambda_1 + \tau} \cdot \left(1 + \frac{1}{2}\lambda_1 + O(\tau^2)\right) \left(1 - \frac{1}{2}(\lambda_1 - \tau)\right) \\ &\sim \frac{\lambda_1}{\lambda_1 + \tau} \cdot \left(1 + \frac{\tau}{2} + O(\tau^2)\right). \end{aligned}$$

Substituting this result into (F) yields

$$P \sim \frac{\lambda_1}{\lambda_1 + \tau} \cdot \left(1 + \frac{\tau}{2} + O(\tau^2)\right) \cdot \frac{1 + \xi^{-1}\tau u_1 + O(\tau^2)}{1 + \xi^{-1}\tau u_1 \cdot \frac{\lambda_1}{\lambda_1 + \tau} + O(\tau^2)}. \quad (\text{G})$$

4. The denominator in the last factor of (G) can be expanded as a geometric series, yielding

$$P \sim \frac{\lambda_1}{\lambda_1 + \tau} \cdot \left(1 + \frac{\tau}{2} + O(\tau^2)\right) \cdot \left(1 + \xi^{-1}\tau u_1 \cdot \frac{\tau}{\lambda_1 + \tau} + O(\tau^2)\right);$$

since $\tau u_1 = \lambda_1 + \tau$, we have

$$P \sim \frac{\lambda_1}{\lambda_1 + \tau} \cdot \left(1 + \frac{\tau}{2} + O(\tau^2)\right) \cdot (1 + \xi^{-1}\tau + O(\tau^2)). \quad (\text{H})$$

5. Expansion of the formula for λ_1 yields the results

$$\lambda_1 \sim (ab - 1)\tau[1 - ab\xi^{-1}\tau + O(\tau^2)], \quad \lambda_1 + \tau \sim ab\tau[1 - (ab - 1)\xi^{-1}\tau + O(\tau^2)],$$

so

$$\begin{aligned} \frac{\lambda_1}{\lambda_1 + \tau} &\sim \frac{ab - 1}{ab} \cdot [1 - ab\xi^{-1}\tau + O(\tau^2)] \cdot [1 + (ab - 1)\xi^{-1}\tau + O(\tau^2)] \\ &\sim \left(1 - \frac{1}{ab}\right) [1 - \xi^{-1}\tau + O(\tau^2)]. \end{aligned}$$

Substituting this last result into (H) yields the desired final result

$$P \sim \left(1 - \frac{1}{ab}\right) \left(1 + \frac{\tau}{2}\right) + O(\tau^2). \quad (\text{I})$$

Received xxxx 20xx; revised xxxx 20xx.

E-mail address: gledder@unl.edu

E-mail address: dsylvest@seattleu.edu

E-mail address: rbouchat@iup.edu

E-mail address: jthiel@citytech.cuny.edu